

FB Series

Electric Counterbalance • 4 Wheel Pneumatic Tyres
80 Volt AC Power • **4.0 – 5.0 tonnes**

FB40
FB45
FB50

Clean and quiet... with power to spare

If you need an electric forklift with extra strength to handle your heaviest jobs, this range of high-capacity AC-powered trucks is the answer.

Ideal for both indoor and outdoor use, it combines extraordinary levels of performance with supreme ergonomics, excellent safety and low operating costs.

Frame and body

- **Robust frame** offers exceptional durability in all working conditions.
- **Low centre of gravity** means stable, safe operation.
- **Stylish overhead guard** gives better strength and protection, and allows quick, easy, secure fitting of cabin panels.

Mast and fork assembly

- **Exceptional visibility** – through the revolutionary high-strength, clear-view mast – maximises driver safety and output.
- **Standard backrest** aids load stability.

Drive

- **Powerful AC drive motor** provides high torque – even at fast speeds – for rapid acceleration, great ramp performance and smooth, quiet, controlled operation.
- **High energy efficiency of AC motors** – together with highly efficient energy recycling through strong regenerative braking – means longer shifts and less recharging.
- **Automatic speed reduction** reduces risk of overturning loaded truck while cornering.



FB Series

Electric Counterbalance • 4 Wheel Pneumatic Tyres

80 Volt AC Power • 4.0 – 5.0 tonnes

Characteristics						
1.1	Manufacturer (abbreviation)			Mitsubishi	Mitsubishi	Mitsubishi
1.2	Manufacturer's model designation			FB40	FB45	FB50
1.3	Power source: (battery, diesel, LP gas, petrol)			Electric	Electric	Electric
1.4	Operator type: pedestrian, (operator)-standing, -seated			Seated	Seated	Seated
1.5	Load capacity	Q	(kg)	4000	4500	4.990
1.6	Load centre distance	c	(mm)	500	500	500
1.8	Load distance, axle to fork face	x	(mm)	510	510	510
1.9	Wheelbase	y	(mm)	2000	2000	2000
Weight						
2.1	Truck weight, without load / including battery (simplex mast, lowest lift height)		kg	6600	6950	7300
2.2	Axle loading with maximum load, front/rear (simplex mast, lowest lift height)		kg	9700 / 900	10400 / 1050	11200 / 1100
2.3	Axle loading without load, front/rear (simplex mast, lowest lift height)		kg	3700 / 2900	3700 / 3250	3700 / 3600
Wheels, Drive Train						
3.1	Tyres: V=solid, L=pneumatic, SE=solid pneumatic - front/rear			SE / SE	SE / SE	SE / SE
3.2	Tyre dimensions, front			250-15	250-15	28 x 12.5-15
3.3	Tyre dimensions, rear			21 x 8-9	21 x 8-9	21 x 8-9
3.5	Number of wheels, front/rear (x=driven)			2x / 2	2x / 2	2x / 2
3.6	Track width (centre of tyres), front	b10	(mm)	1120	1120	1150
3.7	Track width (centre of tyres), rear	b11	(mm)	950	950	950
Dimensions						
4.1	Mast tilt, forwards/backwards	α/β	$^{\circ}$	6 / 8	6 / 8	6 / 8
4.2	Height with mast lowered (see tables)	h1	(mm)	2405	2405	2405
4.3	Free lift (see tables)	h2	(mm)	150	150	150
4.4	Lift height (see tables)	h3	(mm)	3000	3000	3000
4.5	Overall height with mast raised	h4	(mm)	4398	4398	4248
4.7	Height to top of overhead guard	h6	(mm)	2320	2320	2320
4.8	Seat height	h7	(mm)	1165	1165	1165
4.12	Tow coupling height	h10	(mm)	390 / 550	390 / 550	390 / 550
4.19	Overall length	l1	(mm)	3980	3980	3980
4.20	Length to fork face (includes fork thickness)	l2	(mm)	2830	2830	2830
4.21	Overall width	b1/b2	(mm)	1340	1340	1450
4.22	Fork dimensions (thickness, width, length)	s / e / l	(mm)	50x125x1150	60x150x1150	60x150x1150
4.23	Fork carriage to DIN 15 173 A/B/no			3A	3A	3A
4.24	Fork carriage width	b3	(mm)	1260	1260	1260
4.31	Ground clearance under mast, with load	m1	(mm)	120	120	120
4.32	Ground clearance at centre of wheelbase, with load (forks lowered)	m2	(mm)	160	160	160
4.33	Working aisle width with 1000 x1200 mm pallets, crosswise	Ast	(mm)	4160	4160	4160
4.35	Turning circle radius	Wa	(mm)	2450	2450	2450
4.36	Minimum distance between centres of rotation	b13	(mm)	670	670	670
Performance						
5.1	Travel speed, with/without load		km/h	15 / 17	15 / 16.5	15 / 16
5.2	Lifting speed, with/without load		m/s	0.35 / 0.47	0.33 / 0.45	0.31 / 0.45
5.3	Lowering speed, with/without load		m/s	0.55 / 0.50	0.55 / 0.50	0.55 / 0.50
5.5	Rated drawbar pull, with/without load		N	5100 / 5600	4900 / 5500	5000 / 5800
5.6	Maximum drawbar pull, with/without load (5 min short duty)		N	14600 / 14900	14500 / 14800	15100 / 15500
5.7	Gradeability, with/without load		%	8 / 13.5	7 / 12	6.5 / 12
5.8	Maximum gradeability, with/without load		%	14 / 23.5	12.5 / 21.5	12 / 21
5.9	Acceleration time (10 metres) with/without load		s	5.0 / 4.4	5.5 / 4.8	5.8 / 5.2
5.10	Service brakes (mechanical/hydraulic/electric/pneumatic)			Hydraulic	Hydraulic	Hydraulic
Electric motors						
6.1	Drive motor capacity (60 min. short duty)		kW	18	18	18
6.2	Lift motor output at 15% duty factor		kW	23.5	23.5	23.5
6.3	Battery to DIN 43 531/35/36 A/B/C/no			43536 A	43536 A	43536 A
6.4	Battery voltage/capacity at 5-hour discharge		V /Ah	80 / 840	80 / 840	80 / 840
6.5	Battery weight		kg	2178	2178	2178
6.6	Energy consumption according to VDI 60 cycle		kWh/h	10.5	11	11.5
Miscellaneous						
8.1	Type of drive control			Impulse AC	Impulse AC	Impulse AC
8.2	Maximum operating pressure for attachments		bar	200	200	200
8.3	Oil flow for attachments		l/min	30	30	30
8.4	Noise level, value at operator's ear (EN 12053)		dB(A)	75	75	75
8.5	Towing coupling design / DIN type, ref.			DIN 15170-H	DIN 15170-H	DIN 15170-H

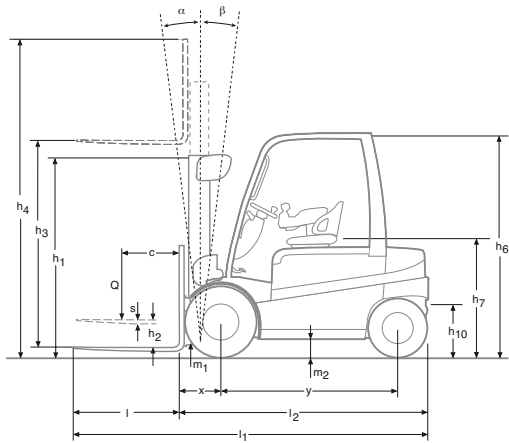

- h1 Height with mast lowered
- h2 Standard free lift
- h3 Lift height
- h4 Height with mast raised
- h5 Full free lift
- Q Lifting capacity, rated load
- c Load centre (distance)

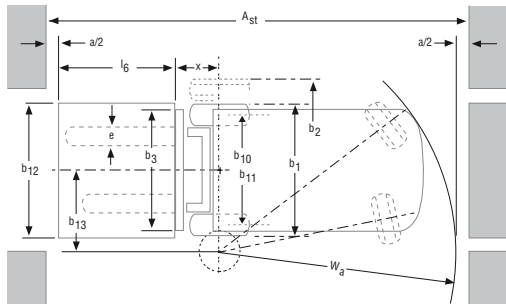

- $A_{st} = W_a + x + l_6 + a$
- Ast = Working aisle width
- Wa = Turning radius
- a = Safety clearance = 2 x 100 mm
- l6 = Pallet length (800 or 1000 mm)
- b12 = Pallet width (1200 mm)



Mast Performance and Capacity

Mast type	FB40-FB45				FB40	FB45
	h3 (mm)	h1 (mm)	h4 (mm)	h2/h5 (mm)	Q @ c=500mm	Q @ c=500mm
Simplex	2750	2280*	4148	150	4000	4500
	3000	2405	4398	150	4000	4500
	3500	2655	4898	150	4000	4500
	4000	2905	5398	150	4000	4500
	4500	3155	5898	150	4000	4500
	5000	3405	6398	150	4000	4500
	5500	3655	6898	150	3650	4100
	6000	3905	7398	150		
Duplex	2950	2205*	4222	1500	4000	4500
	3450	2455	4722	1750	4000	4500
	3950	2705	5222	2000	4000	4500
	4450	2955	5722	2250	4000	4500
Triplex	3800	2080*	5072	1375	4000	4500
	4175	2205*	5447	1500	4000	4500
	4925	2455	6197	1750	3920	4420
	5300	2580	6572	1875	3890	4300
	5675	2705	6947	2000	3750	4200
	6425	2955	7697	2250	3580	3800
	7175	3205	8447	2500	2850	3200

Mast type	FB50				
	h3 (mm)	h1 (mm)	h4 (mm)	h2/h5 (mm)	Q @ c=500mm
Simplex	2750	2280*	3998	150	4990
	3000	2405	4248	150	4990
	3500	2655	4748	150	4990
	4000	2905	5248	150	4990
	4500	3155	5748	150	4990
	5000	3405	6248	150	4750
	5500	3655	6748	150	4400
	6000	3905	7248	150	
	6500	4155	7748	150	
Duplex	2950	2205*	4222	1350	4990
	3450	2455	4722	1600	4990
	3950	2705	5222	1850	4990
	4450	2955	5722	2100	4990
Triplex	3800	2080*	5072	1225	4990
	4175	2205*	5447	1350	4800
	4925	2455	6197	1600	4750
	5300	2580	6572	1725	4700
	5675	2705	6947	1850	4610
	6425	2955	7697	2100	4100
	7175	3205	8447	2350	3500

* lower than overhead guard

Battery compartment	FB40	FB45	FB50
Length (min)	1012	1012	1012
Width (min)	1038	1038	1038
Height (min)	840	840	840
Minimum weight (80V)	2069	2069	2069





when
reliability
is **everything**

Like any product bearing the Mitsubishi name, our materials handling equipment benefits from the huge resources and cutting-edge technology of one of the world's largest corporations. So when we promise you **quality, reliability and value for money**, you know it's a guarantee we have the power to deliver.

Every model in our comprehensive, award-winning range of forklift trucks and warehouse equipment is built to a high specification and is designed to keep on working for you... day after day... year after year... whatever the job... whatever the conditions.

To ensure your truck stays in constant productive action, we have a network of local dealers – hand-picked for their commitment to customer care... and backed up by the Mitsubishi Forklift Trucks organisation. No matter where you are, we have a dealer close by – ready and willing to meet your needs.

That friendly local service covers everything from identifying the perfect model and configuration for your application to providing competitive, flexible finance and maintenance packages, unbeatable warranties, long and short term hire, and highly responsive field service and repairs... as well as the industry's quickest and most reliable parts supply.

Only Mitsubishi can give you this combination of global engineering excellence and outstanding local support... only Mitsubishi offers you such a quality product at such an affordable price... and only Mitsubishi places reliability as high as you do in its priorities. Contact your local dealer now and see what Mitsubishi can do for you.

You can find your nearest dealer at www.mitforklift.com



Steering system

- **Fully hydrostatic steering** means precise control with minimal effort.
- **Brushless DC steering motor** – the most efficient unit for this application – gives a perfect balance between efficiency and economy.
- **Excellent manoeuvrability and stability plus minimal emissions** make these trucks ideal for both indoor and outdoor operations.

Brakes

- **Automatically applied park brake and anti-rollback system** ensures operator safety on ramps.
- **Wet disc brakes** – and highly efficient regenerative braking – mean effective control and minimal brake wear.

Hydraulics

- **Powerful AC hydraulic motor** provides high torque for rapid but smooth – and controlled – lifting and lowering.

Electrical and control systems

- **Advanced MOSFET controller** adjusts acceleration, travel speed, lift/lower speed and braking to suit the load, application and driver – for great versatility.
- **On-board diagnostics and fault memory folder** keep operator and service engineer aware of any problems, speed up servicing and help prevent damage.

Operator compartment and controls

- **Low step** – together with non-slip surfaces, grab handle and rounded overhead guard – gives easy on-off access from both sides.
- **Full-suspension, fully adjustable seat** – with hip restraints and belt – keeps driver safe, comfortable and alert through the longest of shifts.
- **Ergonomic operator compartment** with adjustable steering column and advanced joystick hydraulic control unit, integrated into fully adjustable, comfortable armrest, reduces driver fatigue and increases precision.
- **Emergency switch** instantly shuts down the truck in emergencies.
- **Auto-style pedals** are easy to use – and give good control without leg strain.
- **Clear display** alerts drivers and service engineers to potential problems – helping to avoid damage and encourage maintenance.

Other features

- **Long service interval** reduces cost of ownership and increases productivity.
- **Maintenance-free wet disc brakes and AC motors** reduce service costs.
- **Rapid access features** give quick and easy entry to all areas for checks and maintenance.

Options

- **Range of factory-fitted panel cabins**
- **Integral side shifter**
- **Lighting kit**
- **DC/DC converter**
- **Non-marking and cushion tyres**
- **Fingertip hydraulic control**



MITSUBISHI FORKLIFT TRUCKS

CESM1 184 (08/10)
© 2010 MCFE
Printed in The Netherlands

mitforklift@mcf.nl www.mitforklift.com

NOTE: Performance specifications may vary depending on standard manufacturing tolerances, vehicle condition, types of tyres, floor or surface conditions, applications or operating environment. Trucks may be shown with non-standard options. Specific performance requirements and locally available configurations should be discussed with your distributor of Mitsubishi forklift trucks. Mitsubishi follows a policy of continual product improvement. For this reason, some materials, options and specifications could change without notice.